



6 Output Presco™ Keypad Decoder.

☎ N761

FEATURES

- Compatible with Presco™ PRE, PSE-NI & PSE-IL keypads.
- Split system for maximum security.
- Six (6) Open Collector logic outputs.
- One way code for OU1 activation only.
- Emergency and Duress output feature.
- 125 client programmable user codes.
- Code digits can repeat. i.e. 12321.
- 3 to 7 digit management and user codes.
- Minimum 19 million possible user code combinations.
- Up to 10 keypads can be connected to one decoder.
- 10 year non volatile memory.
- Operating Temperature Range: 0°C to 70°C.

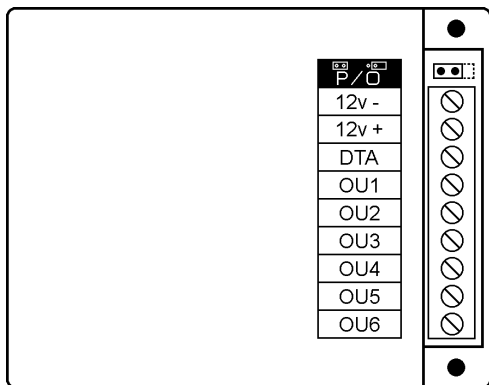

1

SPECIFICATIONS

Power Requirements: 10-15V D.C. @ 15mA.
OU1 to OU6 outputs: Open Collector, 300mA max. sink current per output, 1A max. over all outputs.
Max. KC6/Keypad separation: 1Km (max. return resistance 100Ω. Non shielded).
Dimensions: 88mm x 69mm x 25mm.
Weight: 200gms.

IMPORTANT! Disconnect all power during wiring.
 Do not over-tighten terminal screws on decoder.

DECODER TERMINAL DESCRIPTIONS

- 12V -** Negative output or Ground from Power Supply.
12V + 12 Volt D.C. positive from Power Supply.
DTA Data (white wire from Keypad).
OU1 This output can be set up for timed or toggle operation (refer to memory 8) and operated with a programmed user code. However when it is set for toggle operation (default setting) it can also be turned on (only) using the built in One Way Code of [#E] (a valid OU1 code must be used to turn it off). When connected to a CM8 control panel OU1 acts as the "Remote Switch Input" (RSI) control.
OU2, 3, 4 & 5 These four (4) outputs can be set up for timed or toggle operation (refer to memory 8) and operated with the user codes programmed into their respective memories (2 to 5). When connected to a CM8 control panel OU5 acts as the "Home Mode Input" (HSI) control.
OU6 This output can be set up as either an Emergency/Duress output or a normal output (refer to memory 0). When used as a normal output it can be set for timed or toggle operation (refer to memory 8) and operated with a programmed user code. However when set as the Duress output (default setting) it can only be set for timed operation and codes cannot be assigned to it.

DURESS OPERATION.

When the Duress feature is enabled (default setting in memory 0) the OU6 output operates for the programmed time (refer to memory 8) when either the emergency code of [E] is used or a [E] is inserted into a valid user code. eg. if a valid code for OU1 is 1234E then using the code as *1234E or 12*34E, etc. will operate OU1 as usual but will also operate OU6 for its programmed time.

DISABLING THE EMERGENCY AND ONE WAY CODES.

The One Way Code of [#E] and Emergency code of [E] can be disabled on an individual keypad basis by simply cutting the link on the back of the keypad.

3

Design Philosophy - Problems and Solutions.

- 1/ Most keypads contain the switching relay and control wiring within the keypad housing. A skilled person could easily bypass the keypad function simply by removing it then manipulating the control wiring, a disastrous situation. Presco™ is "split" in 2 parts, so that the decoder can do all the processing at a remote protected environment. The code is transmitted between keypad and decoder in "computer" language, therefore cutting or shorting wires won't compromise security.
- 2/ Typical keypad installations require 7 or more wires thus increasing labour and cost. Presco™ uses only 4 wires to communicate arm/disarm, isolate, emergency, auxiliary, One Way Code, LED/buzzer feedback of code entry, acknowledgment of correct code, state of alarm, previous alarm warning, remote management code programming and power. Up to 10 keypads can be connected to a KC6 by simple parallel wiring. No synchronising is required.

PROTECTION.

The NIDAC Presco™ keypad system has a high immunity to all types of static, EMF, and RF transmissions including those of Police and CB radio systems. Reverse polarity and over voltage protection from lightning strike up to 10Kv is provided.

WARRANTY.

NIDAC SECURITY PTY. LTD. will repair or replace this product if proven to be faulty (excluding accidental or malicious damage) under the 36 month warranty offered from the date of purchase.

As NIDAC SECURITY PTY. LTD. or it's agents do not perform the final installation, inspection or training in the use of this product, they cannot be held liable for injury, loss or damage directly or consequentially arising from the use or misuse of this product.

Presco™ is a registered Trade Mark belonging to NIDAC SECURITY PTY. LTD. The Presco™ Keypad system is protected by provisional and pending patents in various countries including Australia.

The software design is protected internationally and remains the intellectual property of NIDAC SECURITY PTY. LTD.

Design improvement and specifications are subject to change without notice. All designs are copyright 1992 - 2000.

Designed and Manufactured by:
NIDAC SECURITY PTY. LTD.

2 Cromwell Street
 Burwood, Victoria
 Australia 3125

Phone: (03) 9808 6244
 Fax: (03) 9808 9335
 International: 61 3 9808...



Revision 3

2

KC6 Series 3 Instructions.doc 27/08/02

OPERATING MODE RULES

- 1/ **1 beep** = successful code (output turned on).
- 2/ **2 beeps** = successful code (output turned off).
- 3/ **5 beeps** = management code entered.
- 4/ a **long beep** = a non existent code.
 a **pause** then a **long beep** = 5 unsuccessful "tries". (System is locked out for 1 minute).
The [E] and Memory No. are NOT required in the OPERATE mode.
- 5/ Cancel a wrong entry with [E], then re-try.

THE MEMORIES

Memory 0	Memory 1	Memory 2	Memory 3	Memory 4
Enable/disable Duress.	OU1 user codes.	OU2 user codes.	OU3 user codes.	OU4 user codes.
Memory 5	Memory 6	Memory 7	Memory 8	Memory 9
OU5 user codes.	OU6 user codes.	NOT USED.	Timed/toggle set-up.	Management code.

BASIC SETUP SEQUENCE

- 1/ Enable/disable Duress (Currently Enabled). [Memory 0]
- 2/ Set outputs as timed or toggle (Currently OU1 to OU5 toggle and OU6 operates for 2 seconds). [Memory 8]
- 3/ Program MANAGEMENT CODE. [Memory 9]
- 4/ Program USER CODES. [Memories 1 to 6]

NOTE: Use the Program Link for steps 1 to 3 above (and step 4 if the management code is not used). Remove link when finished.

ENABLE/DISABLE DURESS. (MEMORY 0)

Factory preset to: Enabled.

Memory 0 stores whether the OU6 relay acts as a Duress output or a normal output.

- 1/ The program link **must be on**.
- 2/ The single digit after the **0** determines whether Duress is enabled or not. The digit after the **0** must be either **0** or **1**.

Enable/disable Duress [E]

- *0 1E Duress on OU6 Enabled (Warble).
- *0 0E Duress on OU6 Disabled (Warble).

4

TIMED/TOGGLE SETUP. (MEMORY 8)

Factory preset to: OU1 to OU5 toggle, OU6 2 seconds.

Memory 8 stores which outputs are to operate as toggle or timed (operate momentarily between 1 to 20 seconds). Each output (OU1 to OU6) can have different time settings.

- 1/ The program link **must be on**.
- 2/ The **position** of the digit after the 8 represents the output. *i.e.* 1st position=OU1, 2nd position=OU2, etc.
- 3/ OU6 cannot be set to toggle if the Duress feature is enabled and so the 6th digit after the 8 cannot be a 0. However if the Duress feature is disabled, so that OU6 is a normal output, then it can toggle.
- 4/ When changing momentary times, your choice will overwrite any previous settings.
- 5/ The **value** of the digit determines the output's operate time in seconds. 1=1s, 2=2s, 3=3s, 4=4s, 5=6s, 6=8s, 7=11s, 8=15s, 9=20s, 0=TOGGLE.
- 6/ The One Way Code of [#]E for OU1 is disabled if OU1 is set for a timed operation.

Set Output times [] []

- *8 2 0 0 0 0 1 E OU1=2s, OU2 to 5 toggle, OU6=1s (Warble).
- *8 0 5 0 0 0 8 E OU1, 3, 4 & 5 toggle, OU2=6s, OU6=15s (Warble).

PROGRAMMING

PROGRAMMING MODE RULES.

- 1/ The [] key = **Add**.
- 2/ The [#] key = **Delete**.
- 3/ Enter memory number [] for OU1 user codes, [] for the management code, etc.) **before** any programmable information. This ensures the information is directed to the correct memory location.
- 4/ **Warble** = successful **Add** or **Delete**.
- 5/ **Long beep** warns that either codes are already in use, too long or short, or more than 125 codes have been used.
- 6/ Press each digit within 10 seconds after the preceding digit, otherwise information will be lost. If a wrong number is pressed, wait 10 seconds then start again.

NOTES:

- 1/ After trying the example codes below, delete them then add your own unique code/s. Avoid obvious codes like 1234.
- 2/ Up to 125 different user codes can be stored between **Memories 1 to 6**.
- 3/ Repeating digits, including the [#], are allowed in codes *eg.* 2[#]3[#]3 provided that [#] is not the first digit.
- 4/ Codes can be from 3 to 7 digits in length.
- 5/ There are **NO** factory preset codes programmed.

THE MANAGEMENT CODE. (MEMORY 9)

Memory 9 stores the **Management** code which allows the **Program** mode to be entered from any keypad **without** the Program link. Use this feature if regularly changing codes, or the decoder is difficult to access. As supplied, no **Management** code exists.

To add, change or delete the **Management** code, the Program link **must be on**. The digits after the [*]9 are the **Management** code.

Add Management Code [] []

- *9 2 4 6 E 246 is the management code (warble).
- *9 3 6 9 E 369 has now **over written** 246 (warble).
- [] Restore operate mode.

Using the Management code [] []

- 3 6 9 E **Program** mode entered (5 beeps).
- * 1 4 5 6 E 456 added to memory 1 user codes (warble).
- **Operate** mode entered automatically.

Note: that the system automatically returns to the **Operate mode** after a single management function has been performed. *i.e.* add or delete a code. If the management function was not successful, the system still returns to the **Operate mode** (after a long beep).

Note: how 369E replaces the Program link function but with the addition of the 5 beeps to clearly indicate which mode is current. All user code programming examples shown below could be done with the **management code**. 369 is an example only, with the link ON overwrite it with a new code or delete with [#]9[E]. **REMOVE LINK**.

Note: If after entering the **Management mode** you decide not to add or delete a code, then press [E] to return to the **Operate mode**.

Note: If the Management code is forgotten, use the program link to over write the forgotten code with a new code. This feature obsoletes factory preset or "house codes" which can compromise security.

USER CODES. (MEMORIES 1 to 6)

The codes programmed into **Memories 1 to 6** are used to operate the outputs OU1 to OU6 respectively.

- 1/ The digits after the [*] and memory no are the user code.
- 2/ Memory 6 (OU6 codes) can only be programmed if the Duress feature is disabled (memory 0).
- 3/ The same user code **cannot** be used for multiple outputs.

Add user codes [] [] Link on both pins (**Program mode**).

- * 1 5 6 7 E 567 is added for OU1 (warble).
- * 1 6 7 8 E 678 is also added for OU1 (warble).
- * 4 7 8 9 E 789 is added for OU4 (warble).

Try user codes [] [] Park link on 1 pin (**Operate mode**).

- 5 6 7 E OU1 turns on (1 beep).
- 6 7 8 E OU1 turns off (2 beeps).
- 7 8 9 E OU4 turns on (1 beep).

Delete a user code [] []

- # 1 6 7 8 E 678 is deleted from OU1 (warble), 567 remains.

Delete all user codes for an output [] []

- # 1 E Deletes all codes stored for OU1 (warble).
- [] Restore operate mode.

BASIC WIRING DIAGRAM

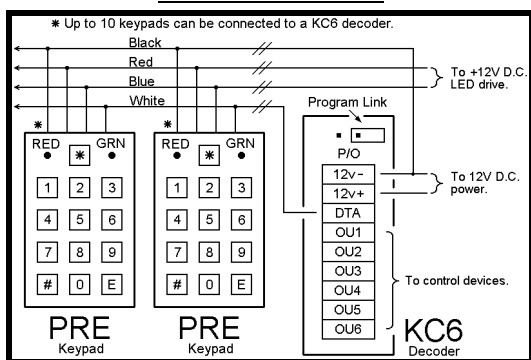

ADDING RELAYS TO OUTPUTS

Use 12 volt, low current relays with contacts of suitable capacity. Note the diode band position. If using the relay for **D.C.** door latch, an extra diode will have to be placed across the latch coil to prevent back EMF spikes from damaging relay contacts. The cathode of this diode connects to the positive side of the strike.

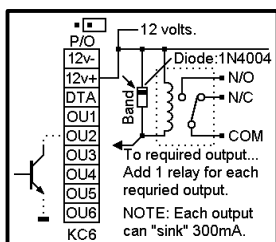

P6 TO CM8 WIRING DIAGRAM

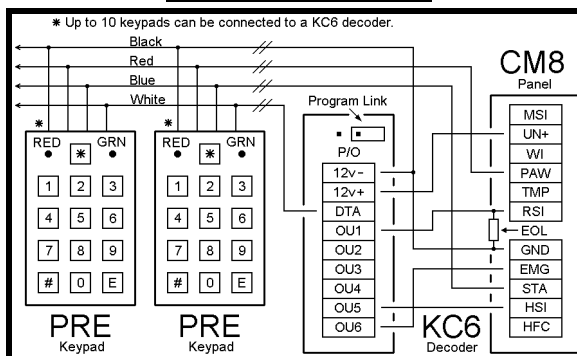

ISOLATION OPTIONS WITH THE CM8

The diagram shows where one code for OU1 totally arms the system (normal mode), and a different code for OU2 simultaneously arms **and** isolates (shunts) the detector/s connected to zone 2.

When isolating, the CM8 "unseal" tone will sound during the exit period as a reminder that isolate is in effect. Other panels will show unseal LED's. Make sure the system is off before rearming to indicate which mode is current. This is not a problem with the CM8 as the unseal tone warns of isolation. The isolate LED option will clearly indicate the isolation mode. Mount this LED in the keypad cover. Use a 1K resistor at the panel. To isolate more zones, add 1 diode for each zone. Connect cathode/s to OU2.

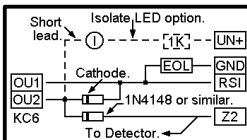

OTHER MODELS AND ACCESSORIES.

- PAC1** 5A. 30V Electric Latch Control relay, programmable as N/O or N/C, 400 timed or toggled user codes, 12-24V D.C. or 16-24V A.C. operation. Door Open Too Long, Door Forced and EGRESS functions built in.
- PAC2** Same features as PAC1 but can control two doors independently.
- KC2** 1 Amp. 30 Volt Control and Duress/Control SPDT relays, timed or toggled operation, 125 user codes, 12 Volt D.C. operation.
- PRE** Standard keypad encoder for any Presco™ decoder.
- PKG** Watertight gasket to increase water resistance of PRE.
- PSE** Metal vandal & weather resistant keypad encoder for any Presco™ decoder. Available as standard (PSE-NI) or back lit (PSE-IL).